

HS2V H02 SERIES

Current Sensor

Model Number

HS2V 200 H02
 HS2V 400 H02
 HS2V 500 H02
 HS2V 600 H02
 HS2V 800 H02
 HS2V 1000 H02
 HS2V 1200 H02
 HS2V 1500 H02

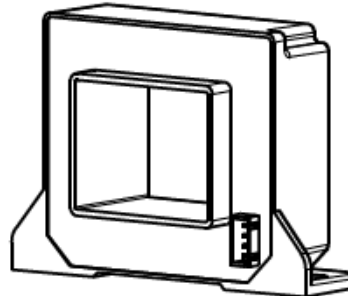

For the electronic measurement of current: DC, AC, pulsed..., with galvanic separation between the primary and the secondary circuits.

Features

- ✧ Open loop current sensor using the Hall effect
- ✧ Galvanic separation between primary and secondary
- ✧ Insulating plastic case recognized according to UL 94-V0
- ✧ No insertion losses
- ✧ Small size
- ✧ Standards:
 - EN50178: 1997
 - IEC 61010-1: 2000
 - UL 508: 2010

Applications

- ✧ AC variable speed
- ✧ Uninterruptible Power Supply (UPS)
- ✧ Static converters for DC motor drives
- ✧ Switch Mode Power Supplies (SMPS)
- ✧ Power supplies for welding applications
- ✧ Battery management
- ✧ Wind energy inverter

Safety

This sensor must be used according to IEC61010-1.

This sensor must be used in electric/electronic equipment with respect to applicable standards and safety requirements in accordance with the following manufacture's operating instructions.

Caution, risk of electrical shock!



When operating the sensor, certain parts of the module can carry hazardous voltage (e.g., Primary busbar, power supply). Ignore this warning can lead to injury and/or cause serious damage.

This sensor is a built-in device, whose conducting parts must be inaccessible after installation. A protective housing or additional shield could be used.

Main supply must be able to be disconnected.

Absolute maximum ratings(not operating)

Parameter	Symbol	Unit	Value
Supply voltage	V_C	V	±15.75
Primary conductor temperature	T_B	°C	100
ESD rating, Human Body Model (HBM)	V_{ESD}	kV	4

- ※ Stresses above these ratings may cause permanent damage.
- ※ Exposure to absolute maximum ratings for extended periods may degrade reliability.

Environmental and mechanical characteristics

Parameter	Symbol	Unit	Min	Typ	Max	Comment
Ambient operating temperature	T_A	°C	-40		85	
Ambient storage temperature	T_S	°C	-40		90	
Mass	m	g		280		
Standards	EN 50178, IEC 61010-1, UL 508C					

Insulation coordination

Parameter	Symbol	Unit	Value	Comment
Rms voltage for AC insulation test @ 50Hz, 1min	V_d	kV	4.9	
Impulse withstand voltage 1.2/50μs	V_w	kV	9	
Clearance (pri.- sec.)	d_{c1}	mm	10	
Creepage distance (pri.- sec.)	d_{cp}	mm	15	
Plastic case	-	-	UL94-V0	
Comparative tracking index	CTI	PLC	3	
Application example	-	-	400V CAT III PD2	Reinforced insulation, according to EN 50178, EN 61010-1
Application example	-	-	800V CAT III PD2	Basic insulation, according to EN 50178, EN 61010-1

HS2V H02 SERIES

Electrical data

※ With $T_A = 25^\circ\text{C}$, $V_C = \pm 15\text{V}$, $R_L = 10\text{k}\Omega$, unless otherwise noted.

Parameter	Symbol	Unit	Min	Typ	Max	Comment
Primary nominal rms current	I_{PN}	A	-200		200	HS2V 200 H02
			-400		400	HS2V 400 H02
			-500		500	HS2V 500 H02
			-600		600	HS2V 600 H02
			-800		800	HS2V 800 H02
			-1000		1000	HS2V 1000 H02
			-1200		1200	HS2V 1200 H02
			-1500		1500	HS2V 1500 H02
Primary current, measuring range	I_{PM}	A	-600		600	HS2V 200 H02
			-1200		1200	HS2V 400 H02
			-1500		1500	HS2V 500 H02
			-1800		1800	HS2V 600 H02
			-2400		2400	HS2V 800 H02
			-3000		3000	HS2V 1000...1500 H02
Supply voltage	V_C	V		± 15		@ 5%
Current consumption	I_C	mA		16		
Load resistance	R_L	k Ω	10			
Output voltage (Analog) @ I_{PN}	V_{OUT}	V	± 3.980	± 4.000	± 4.020	
Electrical offset voltage	V_{OE}	mV	-20		20	
Temperature coefficient of V_{OE}	TCV_{OE}	mV/K	-1		1	@ $-40^\circ\text{C} \sim 85^\circ\text{C}$
Theoretical sensitivity	G_{th}	mV/A		20.00		HS2V 200 H02
				10.00		HS2V 400 H02
				8.00		HS2V 500 H02
				6.67		HS2V 600 H02
				5.00		HS2V 800 H02
				4.00		HS2V 1000 H02
				3.33		HS2V 1200 H02
	2.67		HS2V 1500 H02			
Sensitivity error	ε_G	%	-0.5		0.5	Exclusive of V_{OE}
Temperature of G	TCG	%/K	-0.1		0.1	@ $-40^\circ\text{C} \sim 85^\circ\text{C}$
Linearity error 0.. I_{PN}	ε_L	% of I_{PN}	-0.5		0.5	Exclusive of V_{OE}
Hysteresis offset voltage @ $I_P=0$ after $1 \times I_{PN}$	V_{OM}	mV	-10		10	
Accuracy @ I_{PN}	X	% of I_{PN}	-1		1	Exclusive of V_{OE}
Response time @ 90% of I_{PN}	t_r	μs			5	
Frequency bandwidth(-3dB)	BW	kHz	25			

HS2V H02 SERIES

Dimensions (in mm. 1 mm = 0.0394 inch)

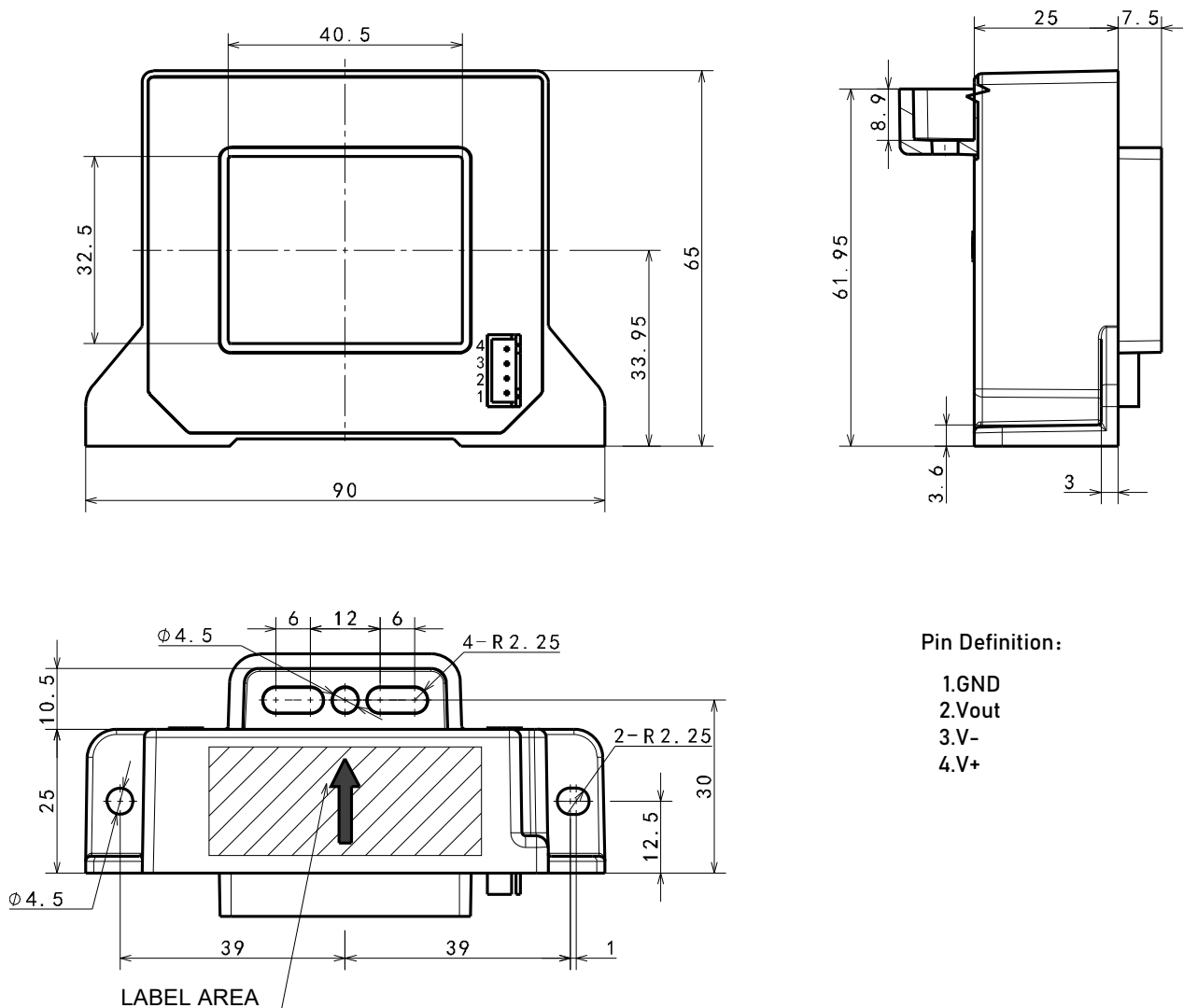

Mechanical characteristics

- ◇ General tolerance ± 0.5 mm
- ◇ Connection of secondary XH-4A
- ◇ Primary hole 40.5mm×32.5mm
- ◇ Sensor 2pc $\Phi 4.5$ mm through hole
2pc M4 metal screws

Recommended fastening torque 2.1 N•m ($\pm 10\%$)

Remarks

- ◇ V_{OUT} and I_P are in the same direction, when I_P flows in the direction of arrow.
- ◇ Temperature of the primary conductor should not exceed 100°C.
- ◇ Dynamic performances (di/dt and response time) are best with a single bar completely filling the primary hole.

This is a standard model. For different applications (measurement, secondary connections...), please contact CHIPSENSE.